

- N.B. : (1) Question No. 1 is compulsory.
 (2) Solve any three questions from the remaining five
 (3) Figures to the right indicate full marks
 (4) Assume suitable data if necessary and mention the same in answer sheet.

Q.1 Attempt any 5 questions [20]

- Compare ideal and practical opamp
- What is crossover distortion in power amplifier. How is it overcome?
- Define differential and common mode gain and differential and common mode input impedance of differential amplifiers.
- Draw the circuit diagram of widlar current source and derive the relationship between output current and reference current.
- Draw high frequency hybrid pi equivalent of BJT and define the various components in the model.
- Explain line regulation and load regulation of voltage regulator. Draw the line and load regulation characteristics of ideal and practical voltage regulator.



Q.2 a) For the circuit shown in Fig. 2a find midband gain and corner frequencies. [10]

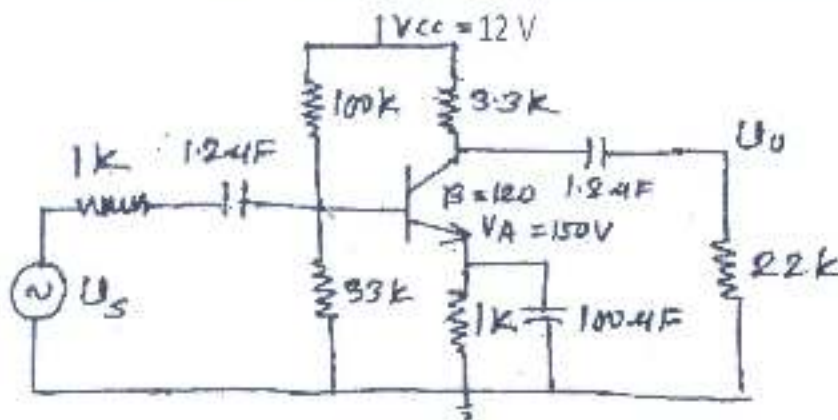

Fig.2a

b) Determine unity gain bandwidth of N channel MOSFET with parameters [10]
 $K_n = 0.25 \text{ mA/V}^2$, $V_{th} = 1\text{V}$, $\lambda = 0$, $C_{gt} = 0.04 \text{ pF}$, $C_{ox} = 0.2 \text{ pF}$, $V_{GS} = 3\text{V}$. If a $10 \text{ k}\Omega$ load is connected to the output between drain and source determine the Miller capacitance and cut-off frequency.

Q.3 a) Draw circuit diagram of MOSFET based differential amplifier and derive the expression for differential gain, common mode gain and CMRR. [10]

b) For the circuit shown in Fig. 3b, find overall mid band voltage gain and capacitors C_{C1} and C_{C2} such that the 3 dB frequencies associated with each stage are equal. Assume BJT to have parameters $V_{BE(sat)} = 0.7 \text{ V}$, $\beta = 200$ and $V_A = \infty$. [10]

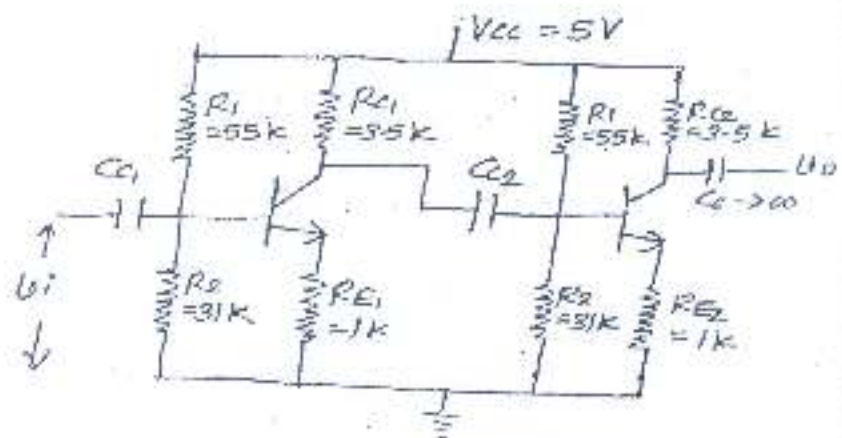

Fig. 3b

Q.4 a) Draw and explain current mirror circuit using MOSFET. For the circuit shown in Fig. 4a determine the value of I_{B1} and I_{O1} . [10]

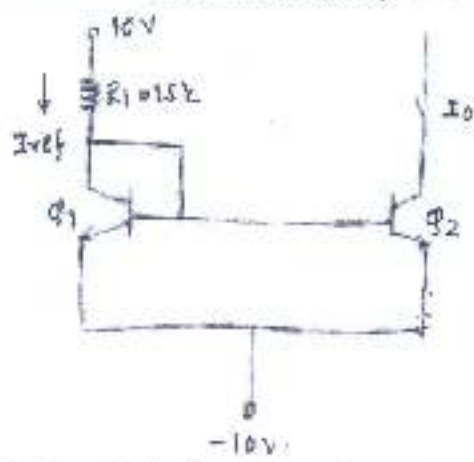

Fig.4a

b) What are the ideal characteristics of opamp and also explain the effect of high frequency on OPAMP gain and phase. [5]

c) Draw the circuit of V_{BE} multiplier biased class AB amplifier and explain the working and advantages of V_{BE} multiplier biased class AB amplifier. [5]

Q.5 a) Draw the circuit diagram of transformer coupled class A power amplifier. Also draw ac and dc loadlines for the same. Derive the expression for its power conversion efficiency. [10]

b) Explain the working of basic differentiator with the help of input and output waveforms. Also derive the expression for the output voltage. What are the limitations of basic differentiator and how to overcome these limitations. [10]

Q.6 - Short notes on: (Attempt any four) [20]

- a) Transistorised series regulator
- b) Power MOSFET
- c) Class AB power amplifier
- d) Active filters
- e) Multistage amplifiers

Q. P. Code: 24361

(3 Hours)

[Total Marks: 80]

N.B. : 1) Question No. 1 is Compulsory.

2) Answer any THREE questions from Q.2 to Q.6.

3) Figures to the right indicate full marks.

- Q.1 (a) If λ is eigen value of A and X is corresponding eigen vector of λ then show that λ^n is eigen value of A^n and corresponding eigen vector is X ($n > 0$). (5)
- (b) Evaluate $\int_C \frac{z^2 - 2z + 4}{z^2 - 1} dz$, where C is $|z - 1| = 1$. (5)
- (c) Find the extremals of $\int_0^1 (1 + x^2 y) y dx$. (5)
- (d) Find a unit vector orthogonal to both $u = (-3, 2, 1)$ and $v = (3, 1, 5)$. (5)
- Q.2 (a) Find eigen values and eigen vectors of $A^2 + 2A$ where $A = \begin{bmatrix} 8 & -8 & -2 \\ 4 & -3 & -2 \\ 3 & -4 & 1 \end{bmatrix}$. (6)
- (b) Find the extremals of $\int_0^1 [(y')^2 - y^2] dx$. (6)
- (c) Obtain Laurent's series expansion of $f(z) = \frac{4z+5}{z^2-z-6}$ at $z=1$. (8)
- Q.3 (a) Using Rayleigh-Ritz method find solution for the extremal of the functional $\int_0^1 [(y')^2 - 2y - 2xy] dx$ with $y(0) = 2$ and $y(1) = 1$. (6)
- (b) Evaluate $\int_3^7 \frac{1}{(x^2-1)(x^2+9)} dx$. (6)
- (c) Show that matrix $A = \begin{bmatrix} -9 & 4 & 4 \\ -8 & 3 & 4 \\ -16 & 8 & 7 \end{bmatrix}$ diagonalizable. Also find diagonal and transforming matrix. (8)

[Turnover]

- Q.4
- a) Verify Cayley Hamilton Theorem for $A = \begin{bmatrix} 1 & 2 & -2 \\ -1 & 3 & 0 \\ 0 & -2 & 1 \end{bmatrix}$. Also find A^{-1} . (6)
- (b) Using Cauchy's Residue Theorem evaluate $\int_0^{2\pi} \frac{d\theta}{3 + 2\cos\theta}$. (6)
- (c) Show that the extremal of isoperimetric problem $I = \int_a^b (y')^2 dx$ subject to the condition $\int_a^b y dx = k$ is a parabola. (8)
- Q.5 (a) Find S^A where $A = \begin{bmatrix} 3 & 1 \\ 1 & 3 \end{bmatrix}$. (6)
- (b) Find an orthonormal basis for the subspace of \mathbb{R}^3 by applying Gram-Schmidt process where $S = \{(1, 1, 1), (-1, 1, 0), (1, 2, 1)\}$. (6)
- (c) Reduce the following quadratic form into canonical form and hence find its rank, index, signature and value class.
 $Q = 5x_1^2 + 26x_2^2 + 10x_3^2 + 6x_1x_2 + 4x_2x_3 + 14x_1x_3$. (8)
- Q.6 (a) State and prove Cauchy-Schwartz inequality. Hence show that for real values of a, b, θ $(a\cos\theta + b\sin\theta)^2 \leq a^2 + b^2$. (6)
- (b) Show that any plane through origin is a subspace of \mathbb{R}^3 . (6)
- (c) Find the singular value decomposition of $A = \begin{bmatrix} 4 & 4 \\ -3 & 3 \end{bmatrix}$. (8)

(REVISED COURSE)

(3 Hours)

[Total Marks: 80]

Note: 1) Q.1 is compulsory

2) Answer any 3 out of remaining questions

- Q.1 (A) Explain the function of SID, TRAP, ALE, and AD0-AD7 pins of processor 8085. (5)
(B) Write features of 8087 math co-processor. (5)
(C) Explain advantages of memory segmentation. (5)
(D) Write control word of 8255 to initialize port-A as input port, port B and C as output port, group A in mode 0 and group B in mode 1. (5)
- Q.2 a) What are different types of interrupt supported by 8086 and explain IVT. (10)
b) Draw and explain the architecture of 80286 processor. (10)
- Q.3 a) Draw and explain the interfacing of Math co-processor with 8086. (10)
b) Explain Minimum mode of 8086 microprocessor. Draw timing diagram for write operation in Minimum mode. (10)
- Q.4 a) Design an 8086 based system with following specifications. (10)
i. 8086 CPU working at 8MHz
ii. 16 KB EPROM using 8K device
iii. 32 KB SRAM using 16K device
b) Describe the importance of 8257 DMA controller. Explain method of interfacing DMA controller with 8086 microprocessor. (10)
- Q.5 a) Write a programme to set-up 8253 as square wave generator with 1 ms period if input frequency of 8253 is 1 Mz (10)
b) Explain Bit Set Reset mode of 8255 with application. (10)
- Q.6 a) Write a program for 8086 to find out the maximum number from the array of 10 numbers. (10)
b) Draw and explain interfacing of ADC 0808 with 8086 Microprocessor using 8255. (10)

NOTE:

1. Question No.1. is compulsory. Attempt any four out of five in it.
 2. Attempt any three out of remaining five.
 3. Assume suitable data, wherever necessary and justify the same.
 4. Figures to the right indicate marks.
1. A) A point charge $Q_1 = 300 \mu\text{C}$ is located at $P_1(1, -1, -3)$ m experiences a force $\vec{F}_{21} = 8 \hat{a}_x - 8 \hat{a}_y + 4 \hat{a}_z$ (N) due to a point charge Q_2 at $P_2(3, -3, -2)$ m. Determine Q_2 . (5)
 - B) What is Ionosphere? Which layers are present during day and night time? Where does maximum attenuation of an electromagnetic wave take place inside the ionosphere? Hence define critical frequency. (1+1+1+1)
 - C) Explain Super refraction and Sub-refraction. (5)
 - D) State the Maxwell's equations for free space in integral and point form. Also state their significance. Which one of these equations tells us the propagation of electromagnetic wave in air? (2+2+1)
 - E) Compare MOM, FEM and FDM. (5)
 2. A) Derive boundary conditions for both Electric and Magnetic fields for conductor-dielectric interface. (10)
 - B) State Poynting theorem. Derive its final expression and explain the meaning of each term. (2+5+3)
 3. A) If the electric flux density $\vec{D} = 4xy \hat{a}_x + 2(x^2 + z^2) \hat{a}_y + 4yz \hat{a}_z$ (C/m^2), using Gauss's Law find the following (10)
 - i) The volume charge density at $(-1, 0, 3)$.
 - ii) The flux through the cube defined by $0 \leq x \leq 2, 0 \leq y \leq 3, 0 \leq z \leq 5$.
 - iii) The total charge enclosed by the cube.
 - B) For the one dimensional differential equation $\frac{\partial^2 V}{\partial x^2} = 0, 0 \leq x \leq 4$. Obtain $V(1)$ using FDM. Given $V(0)=0$ and $V(4)=20$. Perform hand matrix method. (5)
 - C) State some applications of electromagnetism. With the help of neat schematic, explain the working of electromagnetic pump. (1+4)
 4. A) Obtain the reflection and transmission coefficient in case of reflection from perfect dielectric at normal incidence. (10)

- B) Derive an expression for the electric field intensity E due to a conductor of infinite length and having charge density ρ_l . (10)
5. A) Obtain an expression for MUF in terms of d , H and f_o . (5)
 If a high frequency communication link is to be established between two points on the Earth 2000 km away, and the reflection region of ionosphere is at height of 200 km and has critical frequency of 5 MHz, then calculate the MUF for the given path.
- B) Find the maximum distance that can be conveyed by a space wave when the transmitting and receiving antenna heights are 60 m and 6 m respectively. Assume standard atmosphere. (5)
- C) With regards to the ionosphere discuss the following: (5)
 i) E layer
 ii) Sporadic E layer
6. A) Derive wave equations in lossy media. (10)
- B) A media has the following properties $\epsilon_r = 1$; $\mu_r = 1$; $\sigma = 10^{-4}$ (ohm⁻¹m) at 1 GHz. Determine: (5)
 i) Propagation constant
 ii) Attenuation constant in dB
 iii) Wavelength
 iv) Refractive index
 v) Loss tangent
 Is the media behaving like a conductor or dielectric?
- C) Explain formation of duct and condition for duct propagation. (5)

(3 Hours)**[Total Marks: 80]**

N.B.:

1. Question No.1 is compulsory.
2. Attempt any three questions out of the remaining five.
3. Assume suitable data wherever necessary.

1. Answer the following

20

- a) Determine whether the following signals are energy signals or power signals and calculate their energy or power.
 - (1) $x(t) = e^{-4t}u(t)$
 - (2) $x(n) = \left(\frac{1}{6}\right)^n u(n)$
- b) Determine if following system is memoryless, causal, linear, time invariant.
 $y(t) = a^t x(n)$
- c) Using properties of Fourier transform, determine Fourier transform of $x(t)$
 $x(t) = e^{-3|t-10|} + e^{3|t+10|}$
- d) Find out even and odd components of following signals:
 - (i) $x(n) = u(n) - u(n-5)$
 - (ii) $x(t) = 5 + 7t + 9t^2$
- e) Determine relation between continuous time Fourier Transform and Laplace Transform.



Turn Over

2. (a) Determine Fourier Series representation of following signal: 10

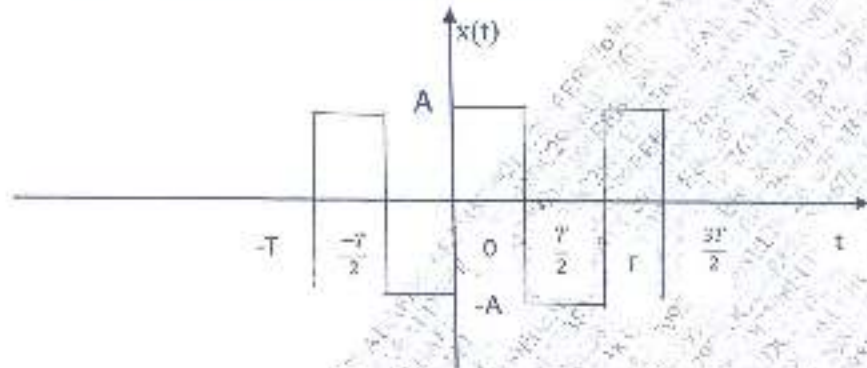

- (b) Find impulse response and step response of continuous time systems governed by following transfer functions. 10

$$H(s) = \frac{s+3}{s^2+6s+8}$$

3. (a) A continuous time signal is defined as, 10

$$x(t) = t, 0 \leq t \leq 3$$

$$x(t) = 0, t > 3$$

Sketch waveforms of following signals:

(i) $x(-t)$

(ii) $x(2-t)$

(iii) $x(3t)$

(iv) $x(0.5t+1)$

- (b) Determine inverse z-transform of following function using long division method: 05

$$X[z] = \frac{z^2+2z}{z^3-3z^2+4z-1} \text{ ROC: } |z| > 1$$

- (c) Compute the DFT of sequence $x(n) = \{0, 1, 2, 3\}$. Sketch magnitude and phase Spectrum. 05

Q4] (a) Using Laplace Transform determine complete response of system described by following Equation. 10

$$\frac{d^2 y(t)}{dt^2} - 6 \frac{dy(t)}{dt} + 8y(t) = \frac{dx(t)}{dt} x(t); \text{ where } y(0) = 1; \frac{dy(0)}{dt} = 3, \text{ for input } x(t) = u(t)$$

(b) Find impulse response of system described by following difference equation 10

$$y(n) - \frac{3}{4}y(n-1) + \frac{1}{8}y(n-2) = x(n) - x(n-1) \text{ where all initial conditions are zero.}$$

5. (a) For the following continuous time signals, determine Fourier Transform. 10

(i) $x(t) = e^{-at} u(-t)$

(ii) $x(t) = \sin \omega_c t u(t)$

(b) Determine Fourier series representation of $x(n) = 4 \cos \frac{\pi n}{2}$ 05

(c) Determine cross correlation of sequence $x(n) = \{1, 2, 2\}$ and $y(n) = \{1, 3, 1\}$ 05

6. (a) The input signal $x(t)$ and impulse response $h(t)$ of a continuous-time system are described as follows 10

$$x(t) = e^{-2t} u(t) \text{ and } h(t) = u(t-1). \text{ Find output of system using convolution integral.}$$

(b) Determine Z Transform and ROC of 10

(i) $x(n) = n^2 u(n)$

(ii) $x(n) = a^n \cos \omega n u(n)$



[Time: Three Hours]

[Marks:80]

- N.B.: (1) Question No. 1 is compulsory.
 (2) Attempt any three out of remaining questions.
 (3) Assume suitable data wherever required.

Q.1 Attempt the following (20)

- a. Compare Linear and Nonlinear Systems
- b. State and explain Mason's gain formula
- c. What is optimal control? Why optimal control is needed.
- d. Define the terms.
 (i) State (ii) State variables (iii) state vector (iv) State Space

Q.2 a. For a system shown below; Calculate its transfer function where $V_o(t)$ is output and $V_i(t)$ is input to the system (05)

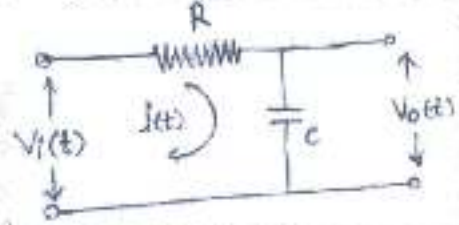

- b. Explain the terms (05)
 (i) Zero input response
 (ii) Zero state response
- c. Explain the concept of Neuro-Fuzzy adaptive control system. Explain one method of adaptive control (10)

- Q. 3 a. Derive the expression of steady state error for a simple closed system using negative feedback (05)
 b. What are the considerations while selecting state variables? (05)
 c. Reduce the given block diagram to its canonical (simple) form and hence obtain the equivalent transfer function $C(s)/R(s)$. (10)

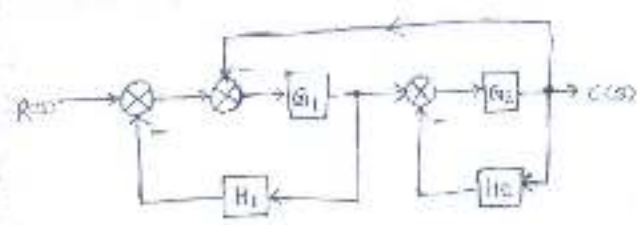

[TURN OVER]

- Q.4. a. Derive the expression for solution of homogeneous equation
 b. Sketch the root locus for the system with

$$G(s)H(s) = \frac{K(s+4)}{s(s^2+2s+2)}$$

- Q.5 a. A unity feedback control system has

$$G(s) = \frac{100}{s(s+0.5)(s+10)}$$

Draw bode plot. Determine G_{pc} , P_{pc} , W_{gc} and W_{pc} . Comment on the stability.

- b. Explain the following terms

- (i) Routh's Criterion
 (ii) Absolute stability and relative stability

- Q.6 a. Derive the expression for Observability proof. Evaluate the Observability of the system

$$A = \begin{bmatrix} 0 & 1 & 0 \\ 0 & 0 & 1 \\ 10 & -2 & -3 \end{bmatrix}; B = \begin{bmatrix} 0 \\ 0 \\ 1 \end{bmatrix} \text{ and } C = [3 \quad 4 \quad 1]$$

Using Kalman's test,

- b. Explain the terms transient response and steady state response.
 c. A unity feedback system has

$$G(s) = \frac{40(s+2)}{s(s+1)(s+4)}$$

Determine (i) type of the system (ii) All error coefficients (iii) Error for ramp input with magnitude 4

.....