

88 : 1ST HALF-13 (r)-JP

Con. 6921-13.

(REVISED COURSE)

GS-5481

(2 Hours)

[Total Marks : 60

- N.B. (1) Question No. 1 is compulsory.
 (2) Attempt any three from remaining five questions.
 (3) All questions carries equal marks.
 (4) Atomic weight :—

H = 1,	Cl = 35.5,
C = 12,	Ba = 137.3,
N = 14,	Mg = 24,
O = 16,	Na = 23,
S = 32,	Ca = 40

1. Answer any five from the following :—

15

- Why silver, gold and platinum do not undergo oxidation corrosion ?
- Define Octane number and Cetane number. Give their significance.
- Give the composition, properties and uses of German silver.
- Give classification of composite material.
- What is Green chemistry ? List the 12 principles of Green chemistry.
- State the characteristics of a good paints.
- A coal sample was subjected to ultimate analysis, 0.6 gm of coal on combustion in a Bomb calorimeter, produces 0.05 gm BaSO₄. Calculate the percentage of 'S' in coal sample.

2. (a) What are metallic coatings ? Distinguish between Galvanizing and Tinning. 6

(b) Explain refining of petroleum with suitable diagram. 5

(c) Calculate % atom economy for following reactions :— 4

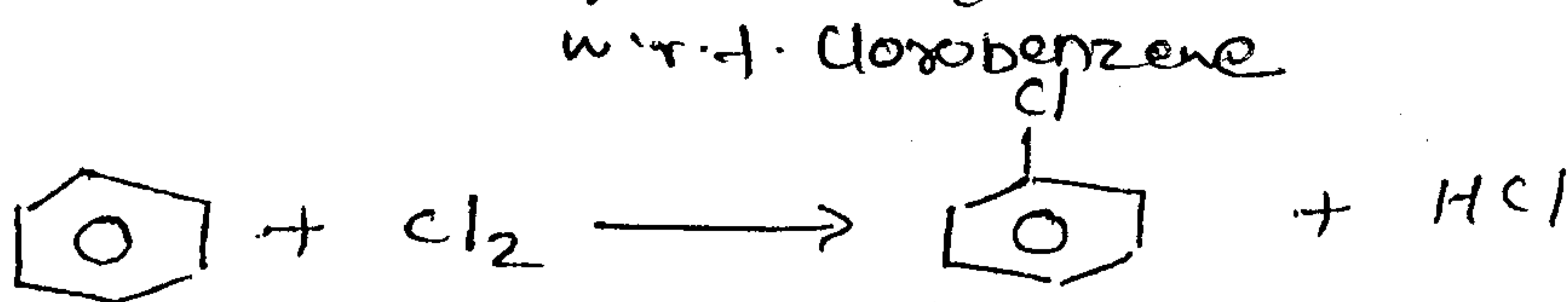

3. (a) A coal sample has the following composition by weights : C = 82%, H = 3%, O = 8%, S = 2%, N = 2% and Ash = 3%. Calculate the minimum amount of air required both by weight and volume for complete combustion of 2 kg of coal. (mol-wt. of air = 28.949 gm). 6

(b) Explain traditional and greener route of production of Indigo dye. By this reactions which principle of green chemistry is shown ? 5

(c) How is the rate of corrosion influenced by :— 4

(i) pH of medium

(ii) Relative area of cathode and anode parts ?

[TURN OVER

Con. 6921-GS-5481-13.

2

4. (a) Write a note on Compacting and Sintering. 6
(b) Explain wet corrosion in acidic medium with schematic diagram and mechanism. 5
(c) Explain Laminar composite with suitable ~~diagram~~ example. 4
5. (a) What is bio-diesel ? Explain the method to obtain bio-diesel from vegetable oil. 6
Give advantages of bio-diesel as a fuel.
(b) Distinguish between Brass and Bronze. 5
(c) State the chemical factors influencing adhesive action. 4
6. (a) What is cathodic protection ? Describe impressed current method of corrosion control. 5
(b) A gaseous fuel has the following composition by volume : 5
 $H_2 = 10\%$, $CH_4 = 30\%$, $C_3H_8 = 20\%$, $CO = 20\%$, $CO_2 = 15\%$, $N_2 = 5\%$.
Calculate the volume of air required for complete combustion of $1m^3$ of this gas.
(c) Explain the effect of following elements on alloying :— 5
(i) Nickel
(ii) Chromium
(iii) Cobalt
(iv) Molybdenum
(v) Tungsten.
-

FE II (CGS) (REV) 01/06/13
Communication Skills

AGJ 1st half (n)con-code 893

Con. 6936-13.

(REVISED COURSE)

GS-5535

(2 Hours)

[Total Marks : 40

N.B. : (1) All questions carry equal marks. Question No. 1 is compulsory. Answer any three of the remaining questions.

(2) Figures to the right indicate marks.

(3) Answers to sub-questions should be grouped together.

Q1. Answer as directed:

[10]

A. Fill in the blanks:

(3)

i) He is one of the men who does/do the work. (Select the correct option)

ii) What's the time _____ your watch? (Fill in the blank with the correct preposition)

iii) The crowd approach is not in keeping with the principle of _____ in business correspondence.

B. Match the columns:

(3)

A	B
a) use of jargon	i) physical barrier
b) resistance to change	ii) barrier in written communication
c) Hierarchical structure	iii) mechanical barrier
d) faulty punctuation	iv) psychological barrier
e) stuttering	v) semantic /linguistic barrier
f) power failure during oral presentation	vi) faulty medium
	vii) status barrier

C. State whether the following are True or False and give reasons for your answer:

(4)

- i) A labeled diagram is an important component of an effective set of instructions.
- ii) "Thanking you in anticipation" is a good ending to a business letter.
- iii) A set of instructions should always end with a list of cautions and warnings.
- iv) Lack of interest in a topic is a receiver-oriented barrier.

Q2. Answer the following questions:

[10]

A. Answer any one of the following:

(4)

- i) Define and explain the process of communication
- ii) Explain the importance of feedback in a communication situation.

B. Distinguish between:

a) Solicited and unsolicited enquiry b) semi-block and modified block format

(2)

b) Fill in the blanks:

(2)

- i) The signature block in a letter consists of the _____, the signature and the name and designation of the writer.
- ii) The principle of _____ implies concern for the needs of the reader.

[TURN OVER

C. Revise the following faulty set of instructions:

(2)

First you should rotate the temperature knob clockwise to 'Toast' and then the dial knob to align with the red tab. After opening the oven door, the wire rack should be inserted in the lowest slot. Finally you can place the bread slices on the rack.

Q3. Answer the following questions as directed:

[10]

A. Answer in one sentence any two of the following:

(2)

- i) What is paralanguage?
- ii) State whether you would use oral or written communication for completing the lease of your apartment and explain why.
- iii) Why is occulesics important in communication?

B. List any two differences between:

(2)

- i) Formal and informal communication.
- ii) Body language and paralanguage

c. You want to renovate your office situated at Ram Mahal, M.G. Road, Fort, Mumbai-400 001. Write a letter of enquiry to Elegant Interior Decorators, Sita Kunj, Cadell Rd, Mumbai, seeking information about the availability of furniture , cost of renovation work schedule etc. Use modified block format. (6)

Q4a). Write short notes on (any three):

[06]

1. Video conferencing.
2. The necessity and importance of feedback
3. The features of listening and hearing.
4. Grapevine Communication.
5. E- Mail Etiquette.

Q4b) Define the following objects:

[4]

Electric iron, tube light, table fan, burette,

Q5a) Describe the process of : sending an email.

[05]

Q5b) State whether following statements are True or False.

[05]

- 1) Acting is a form of communication
- 2) Body language is less important than verbal language.
- 3) In closed punctuation there are commàs after the address.
- 4) The meaning of the message is not in the words
- 5) Extreme emotion enhances communication.

6. (a) Give diagrammatic representations of Horizontal communication, Vertical communication, Diagonal communication. 5
- (b) Read the following passage carefully and answer the questions given below :

Terror-Tech

From the ever-evolving computer industry to the introduction and widespread popularity of the internet, from the various electronic gadgets cars to spacecrafts, the world of technology is seemingly endless. Technology is a powerful tool in this modern era, and it has the capability to influence society for its betterment, as well as destruction.

Terrorism, by far, is the worst reason for which technology can be utilized; unfortunately, however, technology has helped terrorism to grow by leaps and bounds. It has helped terrorism in both actual and cyber terrorism. It takes only a glance at the complex making and build-up of an explosive or bomb to realize that yes; technology has had a worldwide impact on terrorism.

Thus we know that, on one hand, in the long run, terrorism nowadays is based mainly on different types of technology, Manufacturing hi-tech gadgets illegally, that too on a daily basis, using the internet as hub to meet, discuss and plan attacks with fellow terrorists breaking (hacking) into government data systems to wreck havoc are only some of the ways in which terrorists utilize technology. Even now, every Indian shudders when the thought of the 26/11 attacks come to mind, when the whole of Mumbai lost many of her loved ones, including army personnel, police officers, women and children. One question, keeps staring at us in the face –“How did a bunch of young boys keep an entire city under siege? ” The answer lies only in one word – technology. By using sophisticated weapons and gadgets, even a dozen young boys were able to terrorize us. Another example is of the train blasts that happened in Mumbai few years back. News reports state that the bomb inside the train was activated using a cell phone.

Conversely, if advancing technology supports the growth of terrorism, it also means that the government has better ways to defend the country/state against terrorism. Hi-end security measures, such as CCTV cameras, infrared detection, video messages regarding solely for the purpose of reporting unidentified / suspicious objects, are all ways in which government can defend the country and combat terrorist by foiling their plans, Bomb-squads, Bullet- proof jackets are many other ways for police and law enforcement officers to fight terrorism effectively.

Whether technology affects the future of terrorism in both the aforementioned ways, is quite clear. As technology advances, it will propel the ways and means of terrorism. Nevertheless, it will also enable the government to take better, stringent measures to protect the people against terrorist. It simply is the question of who will prevail first. And that, in its entirety, is a very scary thought.

1. Why is technology described as a powerful tool in the passage? [1]
 2. How has technology helped terrorism? [1]
 3. How do terrorists utilize technology? [1]
 4. What are the good uses of technology? [1]
 5. Give one word for: [1]
 - extensively far-reaching
 - Confusion and destruction.
-

F. E. Sem II (Rev)
ED (CGS).
6/ May '2013.

ws-Con-2013-58

Con. 6946-13.

(REVISED COURSE)

GS-5568

(3 Hours)

[Total Marks : 60

N.B.: 1. Question NO 1 compulsory. Attempt any three out of remaining question.

2. All dimensions are in mm.

3. Assume suitable dimensions if necessary.

Q.1 (a) A circular plate of diameter 60 mm rolls without slipping along a straight line inclined at 30° to horizontal. Draw locus of point of its contact with the line if it completes one rotation. Name the curve. [06]

(b) Draw i) Front view. [04]

ii) Top View. [04]

iii) Insert all major dimensions. [01]

Refer Fig. No. 1 (Page 3)

Q.2 Draw i) Front view. [04]

ii) Sectional Top View. [05]

iii) R.H.S. View [04]

iv) Insert all major dimensions. [02]

Refer Fig. No. 2 (Page 3)

Q.3 A pentagonal pyramid side of base 30 mm and axis 60 mm long stands on an edge of base on H.P. The edge makes an angle of 45° with the V.P. Draw its projections if the apex is 40 mm above H.P. and nearer to the observer. [15]

[TURN OVER

Q. 4 (a) A cylindrical block of base diameter 80 mm and height 50 mm is resting on one of the base point on H.P. with axis inclined at 60° to H.P. Draw its projections. [06]

(b) Draw isometric projection using natural scale. Refer Fig. No. 3 [09]

Q.5 A right circular vertical cone, base diameter 50 mm and axis 60 mm long is cut by an AIP and bisecting the axis. Draw Front View, Sectional Top View and True Shape of the Section if True Shape of the Section is an ellipse with major axis is 40 mm. What is the inclination of the cutting plane with H.P.? Also draw Development of Lateral Surface of remaining portion of the solid. [15]

Q.6 (a) Top view and front view of a line AB, 70 mm long measures 55mm and 60 mm respectively. Draw its projections if end A is 15 mm above H.P. and 20 mm in front of V.P. Determine its inclinations with H.P. and V.P. [09]

(b) Draw isometric projection using natural scale [06]

Refer Fig. No.4

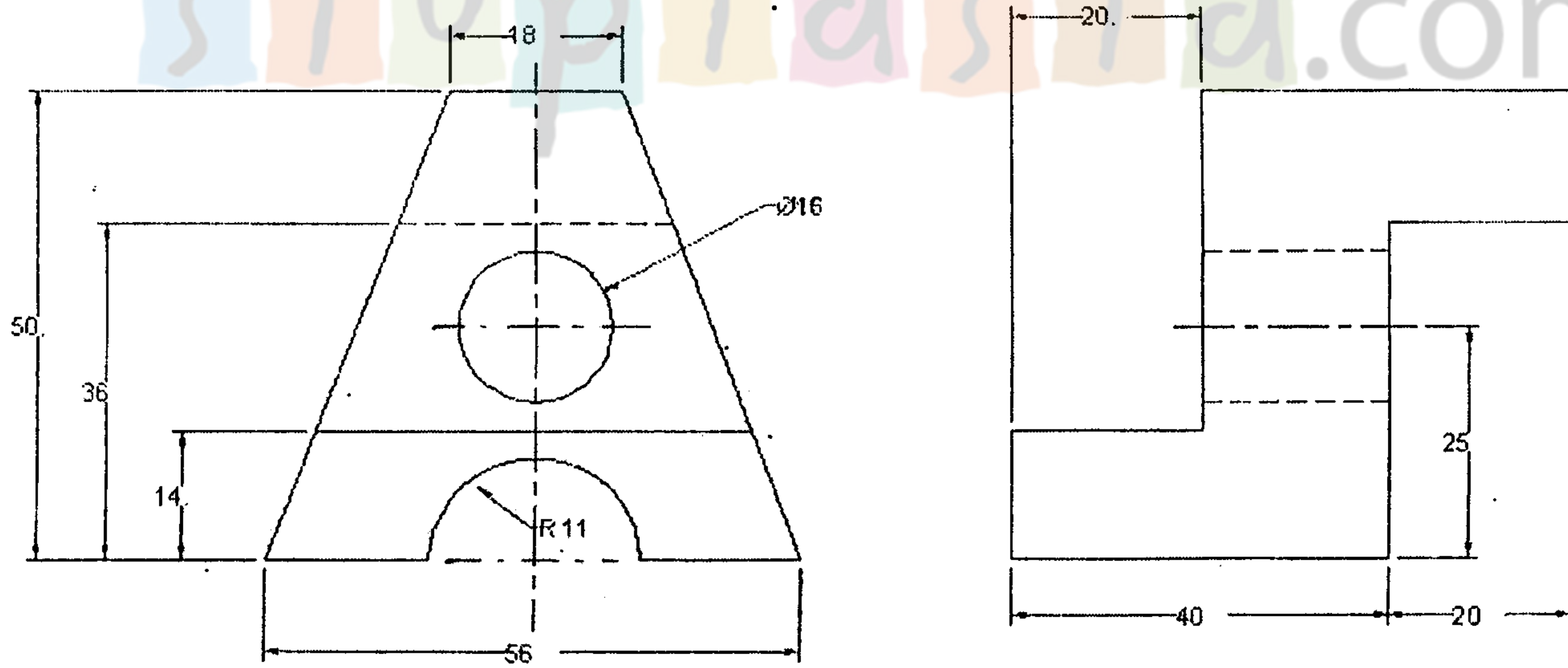
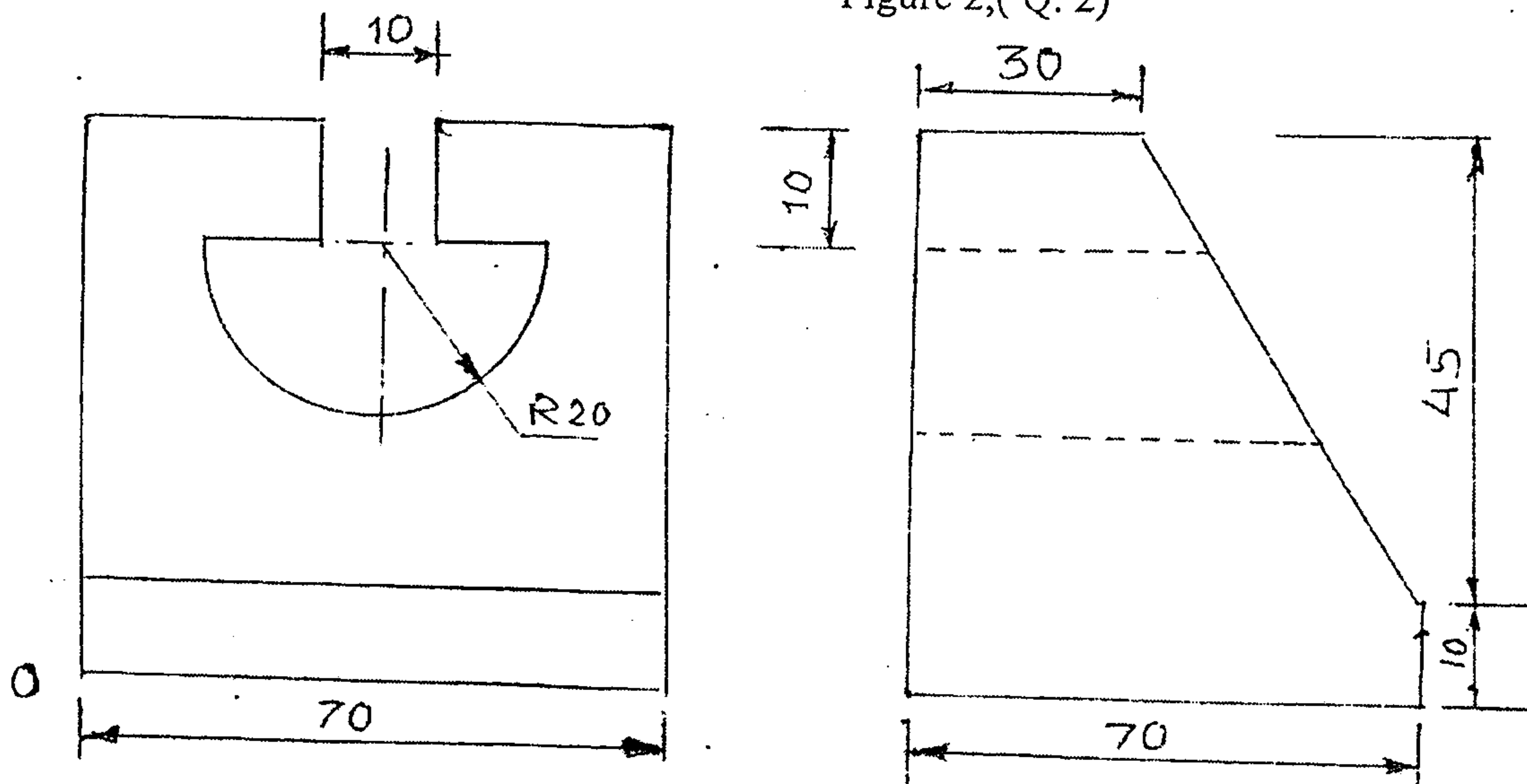
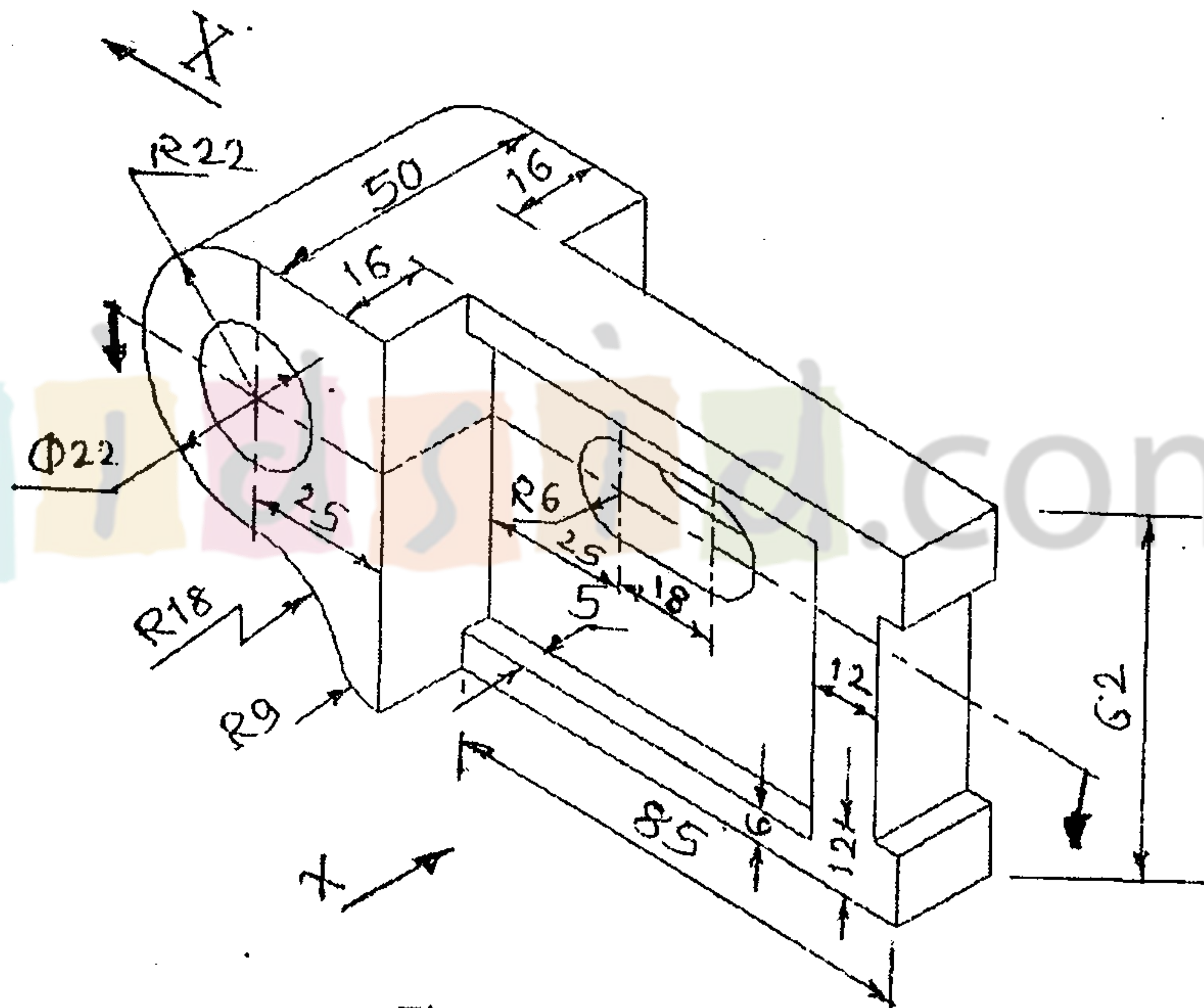
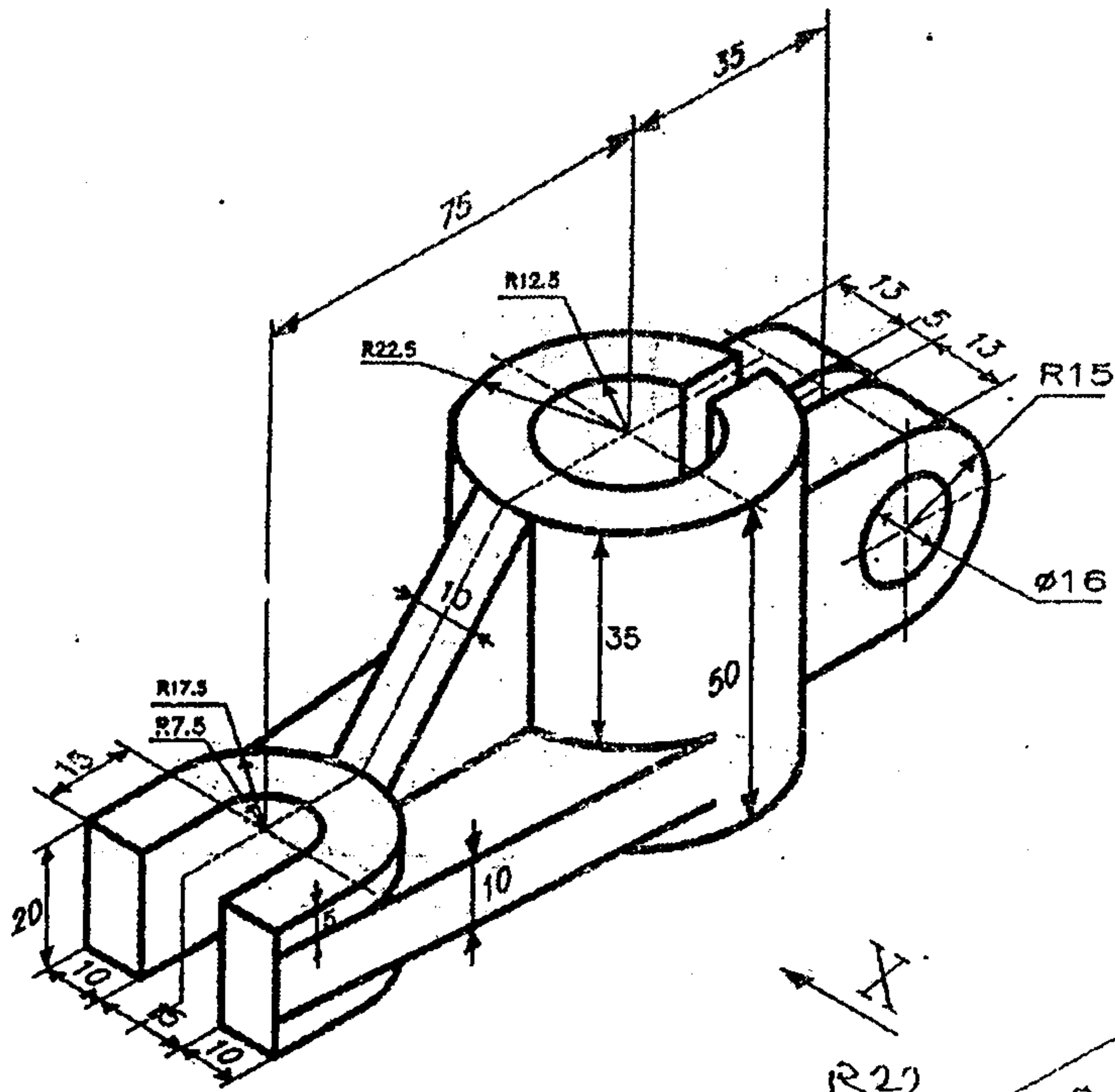

Figure 3(Q4, b)



10/6/2013
Feb. 2013-(e) 97
Con. 6887-13.

F.E Sem II (R)
App. Maths - II

(REVISED COURSE)

(3 Hours)

GS-5427

[Total Marks : 80

- N.B. : (1) Question No. 1 is compulsory.
(2) Answer any three questions from Question Nos. 2 to 6.
(3) Figures to the right indicate full marks.
(4) Programmable calculators are not allowed.

1. (a) Evaluate $\int_0^1 (x \log x)^4 dx$. 3

(b) Solve $(D^2 - 1)(D - 1)^2 y = 0$. 3

(c) prove that $E = 1 + \Delta = e^{hD}$. 3

(d) Solve $\frac{dy}{dx} = \frac{y+1}{(y+2)e^y - x}$ 3

(e) Change into Polar co-ordinates and Evaluate $\int_0^a \int_0^{\sqrt{a^2-x^2}} (x^2 + y^2) dy dx$. 4

(f) Evaluate $\int_0^1 \int_0^{\sqrt{1-x^2}} \frac{dx dy}{1+x^2+y^2}$ 4

2. (a) Solve $(x^3 y^3 - xy) dy = dx$. 6

(b) Change the order of Integration and Evaluate $\int_0^1 \int_x^{2-x} \frac{x}{y} dy dx$. 6

(c) (i) P.T. $\int_0^{\pi/2} \tan^n x dx = \frac{\pi}{2} \sec \left[\frac{n\pi}{2} \right]$. 4

(ii) Evaluate $\int_0^{\infty} \frac{\log(1+ax^2)}{x^2} dx$, $a > 0$ 4

3. (a) Evaluate $\int_0^1 \int_0^{1-x} \int_0^{1-x-y} \frac{dz dy dx}{(1+x+y+z)^3}$. 6

(b) Find the area using Double integration where the region of integration is bounded by the curves $9xy = 4$ and $2x + y = 2$. 6

[TURN OVER

(c) (i) Solve $x^2 \frac{d^2y}{dx^2} - x \frac{dy}{dx} + 4y = \cos(\log y)$. 4

(ii) Solve the equation by method of variation of parameters 4

$$\frac{d^2y}{dx^2} + 3 \frac{dy}{dx} + 2y = e^{e^x}.$$

4. (a) Show that for the parabola $r = \frac{2a}{1+\cos\theta}$ for $\theta = 0$ to $\frac{\pi}{2}$ is a $[\sqrt{2} + \log(1+\sqrt{2})]$. 6

(b) Solve $\frac{d^2y}{dx^2} + 2y = x^2 e^{3x} + e^x - \cos 2x$. 6

(c) Apply Runge-Kutta method of fourth order to find an approximation value of 8

y at $x = 0.2$ if $\frac{dy}{dx} = x + y^2$ given $y = 1$ when $x = 0$ in steps of $h = 0.1$.

5. (a) Solve $(2xy^4e^y + 2xy^3 + y) dx + [x^2y^4e^y - x^2y^2 - 3x] dy = 0$. 6

(b) Solve $\frac{dy}{dx} = 2x + y$ with initial conditions $x_0 = 0, y_0 = 0$ by Taylor's method 6

obtain y as series in powers of x .

Find approximation value of y for $x = 0.2, 0.4$. Compare your result with exact values.

(c) Evaluate $\int_{-1}^1 \frac{dx}{1+x^2}$ by: 8

(i) Trapezoidal method (ii) Simpson's $\frac{1}{3}$ rd method and (iii) Simpsons $\frac{3}{8}$ th method. Compare result with exact values.

6. (a) In a circuit containing inductance L , resistance R and voltage E . The current i is given by 6

$$L \frac{di}{dt} + Ri = E. \text{ Find current } i \text{ at time } t \text{ if } t = 0, i = 0 \text{ and } L, R, E \text{ are constants.}$$

(b) Evaluate $\iint_R xy \, dx \, dy$ where R is the region bounded by $x^2 + y^2 - 2x = 0$, 6
 $y = x$ and $y^2 = 2x$.

(c) (i) Find volume of tetrahedron bounded by plane $x = 0, y = 0, z = 0$ and 4
 $x + y + z = a$.

(ii) Find volume bounded by cone $z^2 = x^2 + y^2$ and Paraboloid $z = x^2 + y^2$. 4

- N.B. : (1) Question No. 1 is compulsory.
(2) Attempt any **three** questions from Q. 2 to Q.6.
(3) **Figures** to the **right** indicate **full** marks.
(4) Assume **suitable** data wherever **necessary**.

1. Attempt any five :-

- (a) A glass material A with which an optical fibre is made has a refractive index of 1.55. This material is clad with another material whose refractive index is 1.51. The light in the fibre is launched from air. Calculate the numerical aperture of the fibre. 3
- (b) Suppose that in the experiment on Newton's Rings, first light of red colour is used and then blue light, which set of rings would have larger diameter? Justify your answer with proper expression. 3
- (c) What is a population inversion state? Explain its significance in the operation of laser? 3
- (d) In a plane transmission grating, the angle of diffraction for second order principal maximum for the wavelength 5×10^{-5} cm is 30° . Calculate the number of lines/cm of the grating surface. 3
- (e) An electron is bound in an one dimensional potential well of width of 2\AA , but of infinite height. Find its energy values in the first excited state. 3
- (f) Explain the measurement of frequency of AC signal using CRO. 3
- (g) Define superconductivity and explain critical magnetic field and critical temperature of a superconductor. 3

2. (a) With the help of a proper diagram and necessary expression, explain how Newton's ring experiment is useful to determine the radius of curvature of a plano convex lens. In a Newton ring's experiment the diameter of 5th ring was 0.336 cm and the diameter of 15th ring is 0.590 cm. Find the radius of curvature of plano-convex lens if the wavelength of light used is 5890\AA . 8

(b) What is dispersion in optical fibres? Mention any three dispersion you have studied and explain any one in detail. 7

Compute the maximum radius allowed for a fibre having core refractive index 1.47 and a cladding refractive index 1.46. The fibre is to support only one mode at a wavelength of 1300m.

[TURN OVER

Con. 6890-GS-5454-13.**2**

3. (a) With a neat energy level diagram describe the construction and working of He-Ne laser. 8
What are its merits and demerits.
- (b) A plane wave of monochromatic light falls normally on a uniformly thin film of oil, 7
which covers a glass plate. The wavelength of the source can be varied continuously.
Complete destructive interference of reflected light is observed for 5000\AA and 7000\AA
and for no other wavelengths in between. Find the thickness of the oil layer. Given
that refractive index of oil is 1.3 and glass is 1.5.
4. (a) Monochromatic light of wavelength 6560\AA falls normally on a grating 2 cm wide. The 5
first order spectrum is produced at an angle of $16^\circ 17'$ from the normal. Calculate total
no. of lines on the grating.
- (b) An electron has a speed of 400m/s. with uncertainty of 0.01%. Find the accuracy in 5
its position.
- (c) Distinguish between Type I and Type II superconductors. 5
5. (a) Derive the condition for absent spectra in grating. 5
(b) Show that the energy of an electron in the box varies as the square of natural numbers. 5
(c) What are different techniques to synthesize nanomaterial ? Explain one of them in detail. 5
6. (a) A bullet of mass 40 gms and an electron both travel at velocity of 1100 m/s. What 5
wavelengths can be associated with them ? Why the wave nature of bullet is not revealed
through diffraction effect.
- (b) Derive Bethe's law for electron refraction. 5
(c) Draw the schematic diagram of SEM and explain its construction and working. 5
-

Con. 6927-13.

GS-5508

(REVISED COURSE)

(3 Hours)

[Total Marks : 80

- N.B.** (1) Question No. 1 is compulsory.
 (2) Attempt any **three** questions from remaining.
 (3) **All** questions carry **equal** marks.
 (3) Assume suitable **data** wherever **necessary**.
1. (a) Explain the purpose of following standard library functions – 3
 (i) Floor () (ii) ceil () (iii) sqrt ()
 - (b) Explain how problem is defined with a help of suitable example. 4
 - (c) Explain difference between for, while and do while loop. 3
 - (d) Explain difference between call by value and call by reference. 4
 - (e) Explain any three string standard library functions. 3
 - (f) Explain reference and de-reference operators with example. 3
 2. (a) Explain various storage classes used in c with example. 5
 - (b) Write a program to calculate sum of list by passing array to a function. 5
 - (c) Write a c-program to create an array of structure to store the details of almost 100 10
 employees. And sort it according to employee ID. Employee details are as follows :
 (i) Employee Name
 (ii) Employee ID
 (iii) Employee Salary.
 3. (a) Write an algorithm and draw flowchart to calculate roots of quadratic equation. 6
 - (b) Write a program to display pascal triangle. 6
 A
 A B
 A B C
 A B C D
 A B C D E
 - (c) Explain recursion concept. Write a program to display Fibonacci series using recursion. 8
 4. (a) Write an algorithm to sort set of numbers in ascending order. For above problem 6
 in which cases time complexity is calculated.
 - (b) Write a program to display armstrong nos between 1 to 1000. 6
 - (c) Write a program to calculate matrix multiplication and transpose for a matrix. 8

[TURN OVER

Con. 6927-GS-5508-13.

2

5. (a) Write a output for following program :-

6

```
# include <stdio.h>
Void main ( )
{
    int x = 10, y, z;
    z = y = x;
    y-- = -- x;
    z-- = x --;
    x-- = -- x -- x --;
    printf ("x = %d y = %d z = %d," x, y, z);p
}
```

(b) WAP to calculate sum of series

 $1/2 + 3/4 + 5/6 + \dots + n$ terms.

6

(c) Write a program to sort list elements in descending order.

8

6. (a) Explain difference between switch statement, ladder of if else and nested if else.

6

(b) Write a recursive program to calculate factorial of accepted number.

6

(c) Write a program to validate whether accepted string is palindrome or not.

5

(d) Explain how to read the contents of file and write into the file with Syntax.

3
