

Duration: 3 hours

Max. Marks: 80

N.B. (1) Question No. 1 is **COMPULSORY**.(2) Answer **ANY THREE** questions from Q.2 to Q.6.

(3) Figures to right indicate full marks.

- Que. 1**
- a. Find Laplace Transform of  $t \cos 4t \cdot \cos 7t$  5
- b. Find Fourier series expansion of  $f(x) = x$  in  $(-\pi, \pi)$  5
- Find the orthogonal trajectory of the family of curves given by 5
- c.  $2x - x^3 + 3xy^2 = a$
- d. If  $A = \begin{bmatrix} -1 & 4 \\ 2 & 1 \end{bmatrix}$ , Find eigen values of  $A^3 - 3A^2 + 5A$  5
- Que. 2**
- a. Obtain Fourier series expansion for  $f(x) = x^2$  in  $(0, 2\pi)$  6
- By using partial fractions, find the inverse Laplace transform of 6
- b.  $\frac{s^2}{(s^2+9)(s^2+16)}$
- Find the eigenvalues and the eigenvectors of the matrix 8
- c.  $A = \begin{bmatrix} 3 & 10 & 5 \\ -2 & -3 & -4 \\ 3 & 5 & 7 \end{bmatrix}$
- Que. 3**
- a. Find the analytic function whose real part is  $\frac{\sin 2x}{\cosh 2y + \cos 2x}$  6
- b. Find the Laplace transform of  $\sinh^5 t$  6
- Using Bender Schmidt method, solve  $\frac{\partial^2 u}{\partial x^2} - \frac{\partial u}{\partial t} = 0$ , subject to 8
- c.  $u(0, t) = 0, u(1, t) = 0, u(x, 0) = \sin \pi x \quad 0 \leq x \leq 1$
- Que. 4**
- a. By using Laplace transform, evaluate,  $\int_0^\infty \frac{\cos 3t - \cos 5t}{t} dt$  6
- Find a, b, c, d, e if 6
- b.  $f(z) = (ax^4 + bx^2y^2 + cy^4 + dx^2 - 2y^2) + i(4x^3y - exy^3 + 4xy)$  is an analytic function. Obtain the half range cosine series of  $f(x) =$  8
- c.  $\begin{cases} x & 0 < x < \pi/2 \\ \pi - x & \pi/2 < x < \pi \end{cases}$

- Que. 5**
- a. Find the analytic function  $f(z) = u + iv$ , in terms of  $z$ , if  $u = y^3 - 3x^2y$  6
- b. If  $L\{f(t)\} = \frac{s}{s^2 + s + 4}$ , find  $L\{e^{-2t} f(2t)\}$  6
- c. Determine if the matrix  $A = \begin{bmatrix} 6 & -2 & 2 \\ -2 & 3 & -1 \\ 2 & -1 & 3 \end{bmatrix}$  diagonalizable, hence find its diagonal matrix  $D$  and modal matrix 8

- Que. 6**
- a. Determine the Half Range Sine Series for  $f(x) = \frac{x(\pi^2 - x^2)}{12}$ , where  $0 < x < \pi$ . 6
- b. Find inverse Laplace transform of  $\cot^{-1}\left(\frac{s+3}{2}\right)$  6
- c. Using Crank- Nicholson simplified formula, solve  $\frac{\partial^2 u}{\partial x^2} - \frac{\partial u}{\partial t} = 0$ , 8  
 $u(0, t) = 0$ ,  $u(4, t) = 0$ ,  $u(x, 0) = \frac{x}{3}(16 - x^2)$  for one step for time.

\*\*\*\*\*

Duration: 3hrs

[Max Marks:80]

- N.B. : (1) Question No 1 is Compulsory.  
 (2) Attempt any three questions out of the remaining five.  
 (3) All questions carry equal marks.  
 (4) Assume suitable data, if required and state it clearly.  
 (5) Use of steam table and Mollier Diagram is permitted.

- 1 Attempt any Five [20]
- State Zeroth law of Thermodynamics and its significance.
  - A gas undergoes a reversible non- flow process according to the relation  $p = (-3V + 15)$ . Where V is the Volume in  $m^3$  and p is the pressure in the bar. Determine the work done when the volume changes from 3 to 6  $m^3$ .
  - What is meant by thermodynamic property? Define Extensive and Intensive properties with examples.
  - Define Joule Thomson coefficient and state its significance.
  - Draw P-V & T-S diagram for Stirling cycle and Ericsson cycle.
  - Explain the effect of varying back pressure on nozzle performance.
- 2 a) Define perpetual motion Machine second kind. Write two major statements of second law of thermodynamics and explain how the concept of thermal efficiency and coefficient of performance are generated by this law. [10]
- b) 1kg of air at 1 bar and 300K is compressed adiabatically till its pressure becomes 5 times the original pressure. Subsequently it is expanded at constant pressure and finally cooled at constant volume to return to its original state. Calculate the heat and work interactions and change in internal energy for each process and for cycle.  $C_p = 1.005 \text{ KJ/kg K}$ ,  $C_v = 0.718 \text{ KJ/kg K}$  [10]
- 3 a) A refrigerator operates on a reversed Carnot cycle whose coefficient of performance is 5. The evaporator is maintained at a temperature of  $-6^\circ\text{C}$  and the power required to run the refrigerator is 3.5 kw. Determining the refrigerating effect and the condenser temperature of the refrigerator. [06]
- b) Write the Maxwell equation and Clapeyron Equation. [04]
- c) Define the terms Available energy, Un-available energy, useful work, irreversibility and Dead state. [10]
- 4 a) Explain various components of a simple steam power plant with sketch. [06]
- b) Define a) wet steam b) Superheated steam c) Dryness fraction d) Saturation temperature. [04]
- c) Write a short note on the Rankine cycle. [10]
- 5 a) What is cut off ratio? What are assumptions of air standard cycle? Derive an expression for the air standard efficiency of Otto cycle. [10]

- b) What is Difference between Otto Cycle and Diesel Cycle. [10]  
For same compression ratio compare Otto, Diesel cycle with the help of P-V and T-S Diagram.
- 6 a) Explain with sketch one dimensional Isentropic flow through ducts of varying cross-sectional area and list its applications. [10]
- b) How the Enthalpy, Specific Volume and Specific Entropy can be calculated for the wet steam with the help of Steam Table. [10]

\*\*\*\*\*

Duration: 3 Hours

Total Marks: 80

N.B.:

- 1) Question No.1 is compulsory.
- 2) Solve any three from the remaining questions
- 3) Figures to RHS indicate full marks.
- 4) Draw neat sketches wherever necessary.

Q. 1 Solve any Four out of Six.

20

- a) Differentiate between Slip and Twinning.
- b) Differentiate between Ductile fracture and Brittle fracture.
- c) Explain Hardenability Test.
- d) Explain Magnetic particle testing.
- e) Define composite and discuss its classification.
- f) Explain Classical creep curve.

Q. 2 a) Draw and explain Time Temperature Transformation diagram. Also indicate various cooling patterns on the diagram. 10

b) Draw and explain Screw type injection moulding process with its advantages, limitations. 10

Q. 3 a) What is fatigue? Explain fatigue testing in detail. 10

b) How surface hardening different from case hardening? Explain carbonitriding in detail. 10

Q. 4 a) Classify crystal imperfections. Distinguish between Edge and Screw dislocation. 10

b) Derive an expression for Griffith's theory of brittle fracture. 10

Q. 5 a) Explain Peritectic and Eutectic reaction with neat sketch. 10

b) Explain critical resolved shear stress, Derive an expression for the same. 10

Q. 6 Write short notes on (Any four) 20

- a) Classification of materials.
- b) Modes of deformation in materials.
- c) Nano materials and their synthesis route.
- d) Austempering Process.
- e) Isomorphous phase diagram.
- f) Work hardening.

Duration: 3 Hours

Total Marks- 80

- N.B.** 1) First Question (Q.1) is Compulsory.  
2) Attempt any 3 questions from the remaining questions.  
3) Figures to the right indicate full marks.  
4) Proportionate and labeled free-hand sketches would do.

**Q1. Write a short note on (Any four)**

**20**

- (a) Types of Risers.
- (b) Hot working process.
- (c) Hybrid Joining process.
- (d) Thermoplastic plastic.
- (e) Internet of things (IoT) in manufacturing.

**Q2. (a) Write short note on broaching machine and compare of lapping and honing operation.**

**10**

**(b) Write difference between arc welding and gas welding.**

**10**

**Q3. (a) What are the five major steps in casting? Discuss casting defects with causes and remedies.**

**10**

**(b) Explain various sheet metal operations with neat sketches.**

**10**

**Q4. (a) Explain various super finishing operations.**

**10**

**(b) Explain steps involved in powder metallurgy process.**

**10**

**Q5. (a) Describe gear milling process.**

**10**

**(b) Explain polymer moulding techniques.**

**10**

**Q6. (a) What are different sheet metal operations? Explain briefly any two of them.**

**10**

**(b) Explain cloud manufacturing.**

**10**

(3 Hours)

[Total Marks: 80]

- N.B.:** 1. Question number 1 is compulsory.  
 2. Attempt any THREE questions from Q2 to Q6.  
 3. Figures to the right indicates maximum marks.

**Q1** Attempt any FOUR of the following: **20**

- (a) Define:
- |                     |                          |
|---------------------|--------------------------|
| 1. Strain energy    | 4. Proof stress          |
| 2. Resilience       | 5. Modulus of resilience |
| 3. Proof resilience |                          |
- (b) State assumptions made in Euler's theory of column
- (c) A rod of 40 mm diameter and 2 m length is stretched by 2.5 mm. Young's modulus for material is 120 GPa and modulus of rigidity is 40 MPa. Take Poisson's ratio as 0.25. Find out lateral contraction of rod and bulk modulus.
- (d) Calculate slope at the support of a simply supported beam of 10 m length acted upon by a point load of 25 kN at centre of beam.
- (e) Draw SFD for a cantilever beam of 5 m length loaded with UDL of 100 kN/m for entire length of beam and a point load of 50 kN at free end.

**Q2** (a) Draw shear force and bending moment diagrams for the beams loaded as shown in figure. **10**

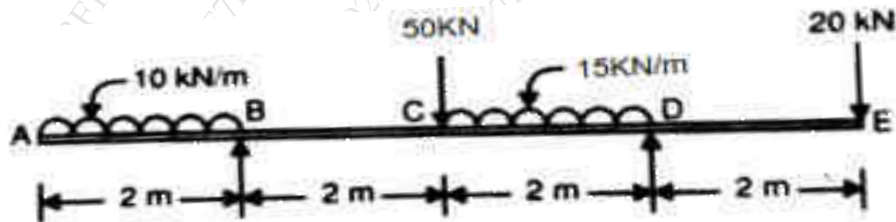

- (b) A 20 mm steel rod passes centrally through a copper tube of 40 mm external diameter and 25 mm internal diameter and 750 mm long. Tube is closed at each end by 25 mm thick steel plates secured by nuts. The nuts are tightened until the copper tube is reduced in length by 0.8 mm. Calculate the stresses in the tube and rod due to tightening. Take,  $E_s = 2 \times 10^5 \text{ N/mm}^2$ ,  $E_c = 1 \times 10^5 \text{ N/mm}^2$ . **10**

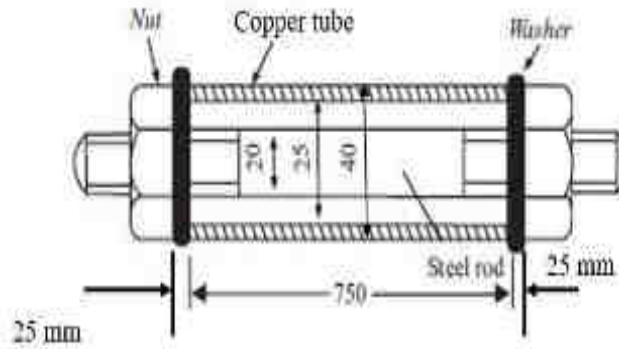

- Q3 (a)** Two mutually perpendicular planes of an element of material are subjected to tensile stress of 105 MPa, compressive stress of 35 MPa and shear stress of 70 MPa. Find graphically or otherwise, **10**
- Magnitude and the direction of principal stresses
  - Magnitude of the normal and the shear stresses on a plane, on which the shear stress is maximum.
- (b)** An unknown weight falls through 8 mm on a collar rigidly attached to the lower end of a vertical bar, 4 m long and 400 mm<sup>2</sup> in section. If maximum instantaneous extension is known to be 3 mm, what is the corresponding stress and the value of unknown weight? Take  $E = 2 \times 10^5 \text{ N/mm}^2$ . **10**

- Q4 (a)** Find slope at point D, Deflections at point B for a beam shown in Fig. Also find the maximum deflection. Take  $E = 2 \times 10^5 \text{ N/mm}^2$  and  $I = 300 \times 10^8 \text{ mm}^4$ . **10**

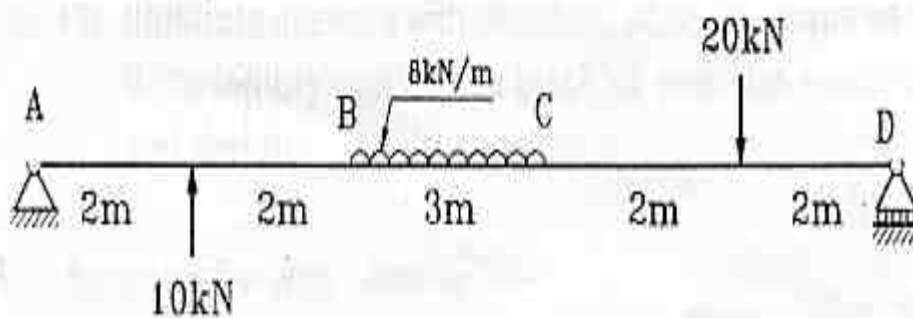

- (b)** A hollow cast iron column has outside diameter 200 mm, it is 4.5 m long and is fixed at both ends. Determine the safe load the column can carry using Rankine's formula. Take metal thickness = 20 mm,  $\sigma_c = 550 \text{ MPa}$ ,  $1/\alpha = 1600$  and  $E = 90 \text{ GPa}$ , FOS = 4 **10**

- Q5 (a)** A closed cylindrical vessel, 4 mm thick carries fluid under a pressure of 3 N/mm<sup>2</sup>. The diameter of the cylinder is 250 mm and length is 750 mm. Calculate the longitudinal and hoop stresses in the cylinder wall of the cylinder. Also calculate maximum shear stress and change in dimensions. Take  $E = 2 \times 10^5 \text{ N/mm}^2$ ,  $1/m = 0.3$ . **10**



- (b) A rectangular block is loaded as shown in figure. Find the change in dimensions and also change in its volume. Take Poisson's ratio = 0.3,  $E=210$  GPa,  $AB=400$  mm,  $BC=120$  mm,  $AE=250$  mm. 10

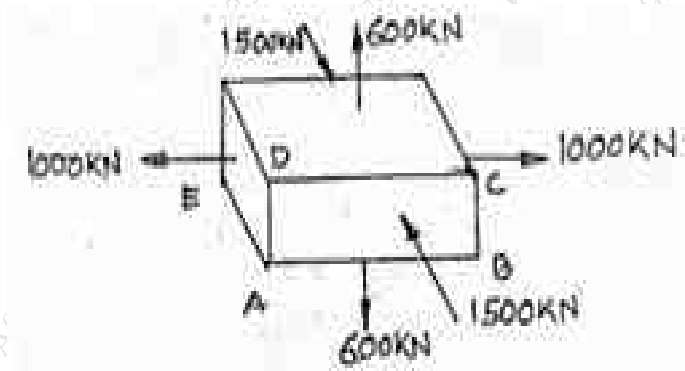

- Q6 (a) For the beam loaded as shown in figure determine deflection at point C and slope at point A. 10

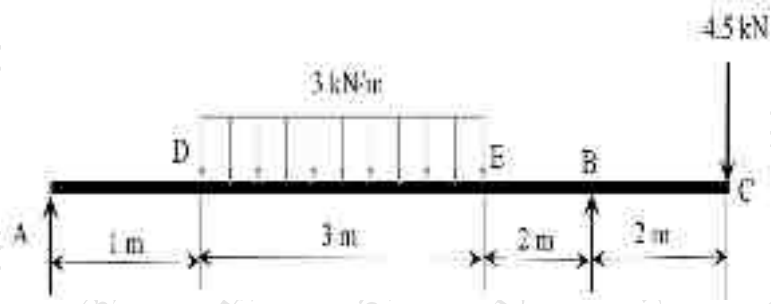

- (b) For the beam loaded as shown in figure draw the Shear force and bending moment diagram. 10

