

Duration: 3hrs**Max Marks: 80**

- N.B. : (1) Question No 1 is Compulsory.
 (2) Attempt any three questions out of the remaining five.
 (3) All questions carry equal marks.
 (4) Assume suitable data, if required and state it clearly.

1 Attempt any FOUR**[20]**

- a** What is the significance of CAD/CAM in the product life cycle, and how does it contribute to the design process?
- b** What are the principles behind Constructive Solid Geometry (CSG) and Boundary Representation (B-Rep) in solid modeling? Provide example of their application.
- c** What is the Homogeneous Coordinate system, and how does it facilitate geometric transformations in computer graphics?
- d** What are the transformation matrices for Pure
 i) 2D rotation about origin, ii) 2D mirroring @ X axis, iii) 2D shearing @ X axis, iv) 3D rotation @ X axis, v) 3D scaling with S_x , S_y & S_z as respective Scaling factors.
- e** Explain the components and functionalities of a machining center.
- f** Explain the socio-economic aspects of Virtual Manufacturing. How does Virtual Manufacturing contribute to cost reduction, product innovation, and sustainable production practices?

- 2 a** Reflect a triangle ABC, A(2,4), B(4,6) & C(2,6) about a line $2y - x - 4 = 0$. Determine (i) the concatenated transformation matrix and (ii) coordinates of the vertices for the reflected triangle. **[10]**

- b** Explain the characteristics of the Bezier curve and plot a Bezier curve having control points as $P_0(1, 0)$, $P_1(3, 3)$, $P_2(6, 3)$ and $P_3(8, 1)$. Take a step size of 0.2. **[10]**

- 3 a** Explain the principles underlying Computed Tomography (CT), Cone beam CT (CBCT), and Magnetic Resonance Imaging (MRI). How do these techniques differ in terms of their applications in medical imaging? **[10]**

- b** Explain the significance of medical scan data in biomedical modeling. How are medical scan data acquired and processed for further analysis? **[10]**

- 4 a Write a manual part program for the finishing the following component as shown in figure. Illustrate the meaning of each code used in the program and the tool movement by showing the tool path. Use the diametral format for programming. [10]

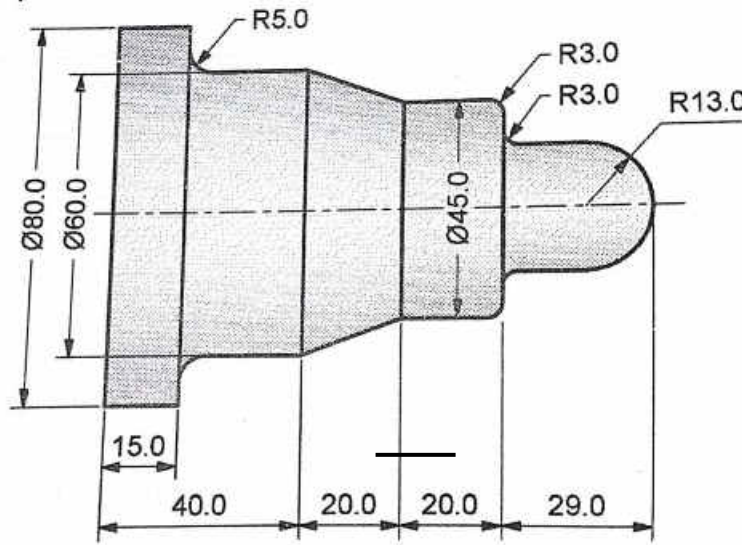

Assume suitable data if needed.

- b In the context of manual part programming, [10]

Explain-

- At least 5 Standard G and M codes need to be included in the beginning and ending of any general program.
- A sample manual program using at least any one canned cycle.

- 5 a Explain the Selective Laser Sintering (SLS) process, including its working principle and key components. How does SLS compare to other additive manufacturing techniques in terms of material compatibility and complexity of parts produced? [10]

- b Compare SLA, SLS, 3D Printing, FDM, and LOM in terms of their working principles and capabilities. [10]

- 6 a Define Virtual Manufacturing and discuss its significance in the modern industrial landscape. What are the primary objectives and scope of Virtual Manufacturing? [10]

- b
- Discuss the potential challenges and limitations of Virtual Manufacturing. [10]
 - Explain the concept of Feature-based Modeling and Constraint-based Modeling in CAD/CAM systems.

(3 Hours)

[Total Marks: 80]

N.B.: 1) Question No. 1 is Compulsory.

2) Answer any THREE questions from Q.2 to Q.6.

3) Figures to the right indicate full marks.

Q.1 (a) Fit a straight line for following data (5)

| | | | | | | | |
|---|----|----|----|----|----|----|----|
| X | 5 | 6 | 7 | 8 | 9 | 10 | 11 |
| Y | 11 | 14 | 14 | 15 | 12 | 17 | 16 |

(b) Let X be a continuous random variable with probability density function (5)

$$f(x) = kx^2(1-x), 0 \leq x \leq 1$$

Find k, mean and variance.

(c) Evaluate $\int_c \bar{z} dz$ where c is unit circle $|z| = 2$. (5)

(d) Can it be concluded that the average life span of an Indian is more than 70 years, if a random sample of 100 Indians has average life span of 71.8 years with standard deviation of 8.9 years? (5)

Q.2 (a) The probability of an item produced by a certain machine will be defective is 0.05. If the produced items are sent to the market in packets of 20 find the number of packets containing at least 2 defective items in consignment of 1000 packets. (6)

(b) Evaluate $\int_c \frac{3z^2+z}{(z^2-1)} dz$ where c is $|z-1| = 1$ (6)

(c) Obtain two lines of regression and coefficient of correlation (8)

| | | | | | | | | |
|---|-----|-----|-----|-----|-----|-----|-----|-----|
| X | 62 | 64 | 65 | 69 | 70 | 71 | 72 | 74 |
| Y | 126 | 125 | 139 | 145 | 165 | 152 | 180 | 208 |

Also estimate Y when X=73.

Q.3 (a) Calculate Correlation coefficient between the variables x and y for the following data (6)

| | | | | | |
|---|----|----|----|----|----|
| X | 10 | 20 | 30 | 40 | 50 |
| Y | 35 | 42 | 55 | 60 | 70 |

(b) Find the work done in moving a particle in the force field $\vec{F} = 3xyi - 5zj + 10xk$ along $x = t^2 + 1, y = 2t^2, z = t^3$ from (2,2,1) to (5,8,8). (6)

(c) The sizes of 10000 items are normally distributed with mean 20cm and standard deviation 4 cm. Find the expected number of items having size: (8)
i) between 18cm and 23 cm, ii) above 26cm.

- Q.4** (a) Following result were obtained from two samples each drawn from two different populations A and B (6)

| Population | A | B |
|-------------|----|----|
| Sample Size | 20 | 17 |
| Sample SD | 60 | 50 |

Test the hypothesis that variance of A greater than variance of B.

Given $(F(0.05) = 2.21 \text{ for } d. o. f. 16 \text{ and } 19)$

- (b) Use Green's theorem to evaluate $\int_c (2x^2 - y^2) dx + (x^2 + y^2) dy$ where c (6)
is the boundary of the surface enclosed by the lines $x = 0, y = 0, x = 2, y = 2$
- (c) Find all possible Laurent's series expansion of the function (8)

$$f(z) = \frac{2-z^2}{z(1-z)(2-z)} \text{ about } z = 0.$$

- Q.5** (a) The sales-data of an item in six shops before & after a special promotional campaign is as follows- (6)

| Shops | A | B | C | D | E | F |
|-----------------|----|----|----|----|----|----|
| Before campaign | 53 | 28 | 31 | 48 | 50 | 42 |
| After campaign | 58 | 29 | 30 | 55 | 56 | 45 |

Can the campaign be judged to be a success at 5% level of significance?

- (b) Using Stoke's Theorem evaluate $\int_c \vec{F} \cdot d\vec{r}$ where $\vec{F} = yi + zj + xk$ and c (6)
is the boundary of the surface of $x^2 + y^2 = 1 - z, z > 0$.
- (c) The theory predicts the proportion of beans in the four groups A, B, C, D (8)
should be 9:3:3:1. In an experiment among 1600 beans, the numbers in the four groups were 882, 313, 287 and 118. Does the experimental result support the theory?

- Q.6** (a) A newly constructed flyover is likely to collapse. The chance that design is faulty is 0.5. The chance that the flyover will collapse if the design is faulty is 0.95 otherwise it is 0.30. If the flyover collapsed what is the probability that it collapsed because of faulty design? (6)

- (b) Three fair coins are tossed. Find the expectation and the variance of the number of heads. Also find moment generating function. (6)

- (c) Show that $\vec{F} = (2xyz^2)i + (x^2z^2 + z \cos(yz))j + (2x^2yz + y \cos(yz))k$ (8)
is conservative. Find scalar potential such that $\vec{F} = \nabla\phi$ and hence, find the work done in displacing a particle from $(0,0,1)$ to $(1,\pi/4,2)$ along the straight line.

Time : 3 Hours

Marks : 80

- N.B:**
- 1) Question No. 1 is **compulsory**.
 - 2) Attempt any **three** questions out of remaining **five** questions
 - 3) Assume suitable data wherever necessary but justify the same
 - 4) Figures to the right indicate Marks

Q1 Solve any Four (20)

1. Explain with neat sketch and example types of constrained motion
2. State any Five CAM terminology
3. Comparison of Cycloidal and Involute tooth forms
4. Classify various types of brakes
5. State and explain D'Alembert's Principle

2 (a) Fig 1 shows a mechanism in which $OA = QC = 100$ mm $AB = QB = 300$ mm $CD = 250$ mm. The crank OA rotates at uniform speed of 150 rpm in clock wise direction. Determine the (a) velocity of slider at D (b) angular velocities of links QB and AB (c) rubbing velocity at the pin B which is 50 mm in diameter (12)

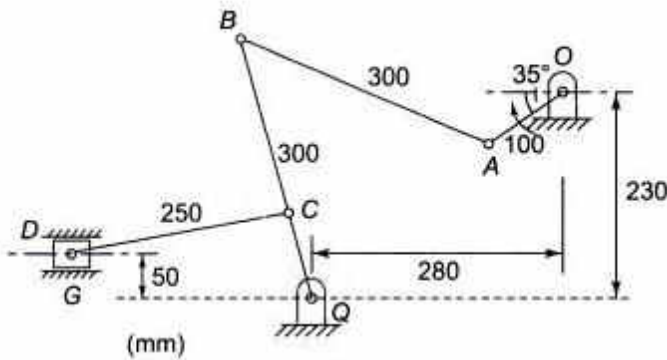

fig 1

(b) Derive the equation for drawing exact straight line using HARTS mechanism (8)

Q 3 (a) In a Whitworth quick return motion, as shown in Fig. 2. OA is a crank rotating at 30 r.p.m. in a clockwise direction. The dimensions of various links are: $OA = 150$ mm; $OC = 100$ mm; $CD = 125$ mm; and $DR = 500$ mm. Determine the acceleration of the sliding block R and the angular acceleration of the slotted lever CA . (14)

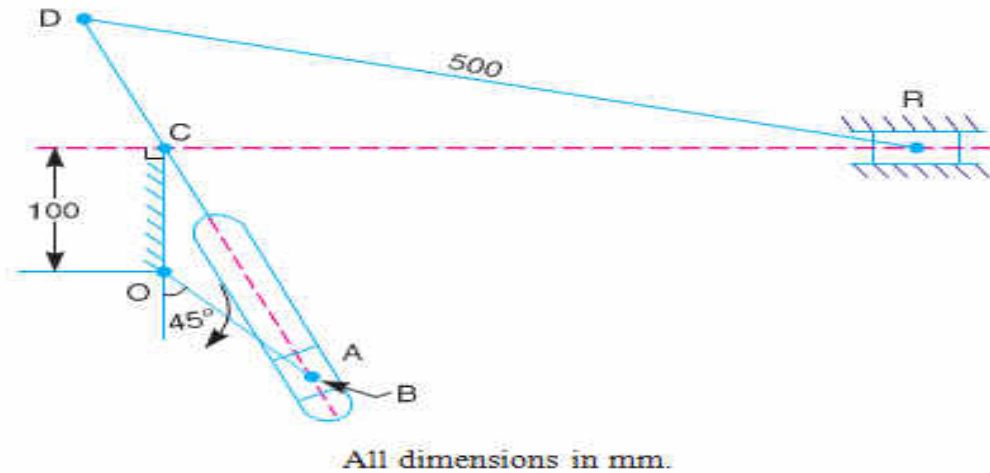

fig 2

(b) With neat sketch explain elliptical trammel (6)

Q 4 (a) Two involute gears in mesh have 20° pressure angle. The gear ratio is 3 and the number of teeth on the pinion is 24. The teeth have a module of 6 mm. The pitch line velocity is 1.5 m/s and the addendum equal to one module. Determine the angle of action of pinion and the maximum velocity of sliding. (10)

(b) A leather belt is required to transmit 7.5 kW from a pulley 1.2 m in diameter running at 250 r.p.m. The angle embraced is 165° and the coefficient of friction between the belt and the pulley is 0.3. If the safe working stress for the leather belt is 1.5 MPa, density of leather 1 Mg/m^3 and thickness of belt 10 mm, determine the width of the belt taking centrifugal tension into account. (10)

Q 5 (a) A roller follower is operated by a uniform rotating cam. The follower is raised through a distance of 25 mm in 120° rotation of the cam, remains at rest for next 30° and is lowered during further 120° rotation of the cam. The raising of the follower takes place with cycloidal motion and the lowering with uniform acceleration and deceleration. The least radius of the cam is 25 mm which rotates at 300 rpm. Plot displacement, velocity and acceleration curves and find the values of the maximum velocity and maximum acceleration during rising and return stroke of the follower. (14)

(b) Classify various types of chains with suitable examples (6)

Q 6 (a) Two shafts A and B are co-axial. A gear C (50 teeth) is rigidly mounted on shaft A. A compound gear D-E gears with C and an internal gear G. D has 20 teeth and gears with C and E has 35 teeth and gears with an internal gear G. The gear G is fixed and is concentric with the shaft axis. The compound gear D-E is mounted on a pin which projects from an arm keyed to the shaft B. Sketch the arrangement and find the number of teeth on internal gear G assuming that all gears have the same module. If the shaft A rotates at 110 r.p.m., find the speed of shaft B. (10)

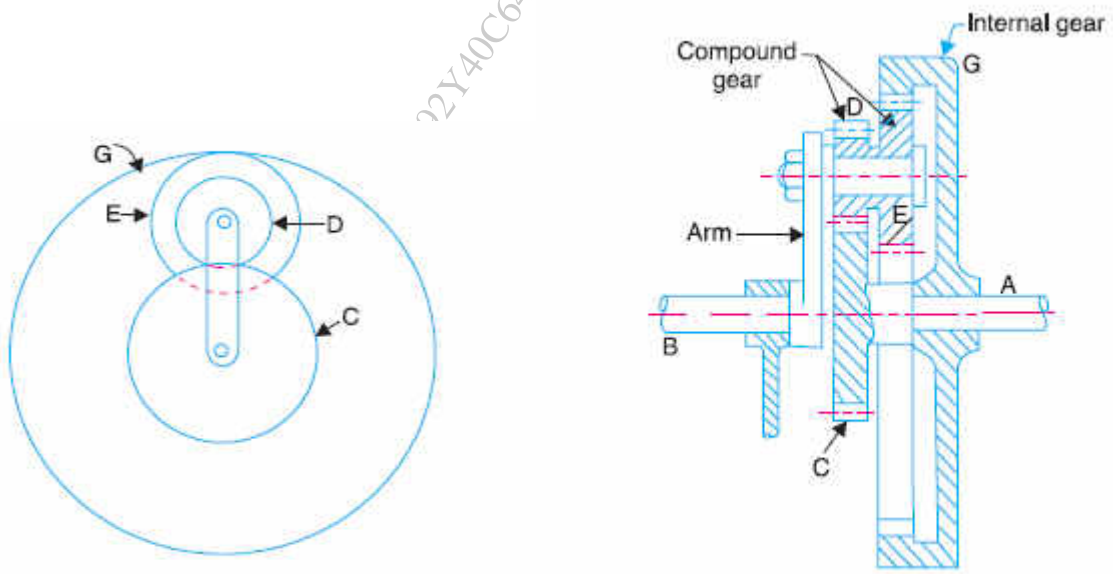

fig 3

(b) State and explain Kennedy's theorem

(5)

(c) Classify kinematic pairs with suitable example

(5)

Duration – 3 Hours

Marks - 80

N.B.: - (1) Question No.1 is compulsory.

(2) Attempt any Three questions out of remaining five questions.

(3) Assume suitable data if necessary and justify the same.

- Q 1. Answer **all** questions.
- A) What are any four parameters used to select a semiconductor device? **04**
 - B) Derive the output equation of Full wave controlled rectifier using SCR. **04**
 - C) Explain the working of Voltage follower or Buffer using OPAMP. **04**
 - D) Describe Set Reset(SR) and Trigger(T) flip flop. **04**
 - E) Explain with block diagram the role of microcontroller in an industrial application **04**
- Q 2 a) Explain any one power electronic switch using construction, working principles and applications. **07**
- Q 2 b) Draw and explain advantages of closed loop speed control over open loop method of speed control in dc motor. **07**
- Q 2 c) Draw VI characteristic of Diac and explain all modes of operation. **06**
- Q 3 a) Identify and describe working of rectifier and inverter used in ac motor speed control. **07**
- Q 3 b) What are similarities and difference between SCR and GTO? **07**
- Q 3 c) Describe with circuit diagram the working OPAMP as an inverting amplifier and non-inverting amplifier **06**
- Q 4 a) Develop circuit using OPAMP for any one industrial application. **07**
- Q 4 b) Explain construction and working of IC555 timer. **07**
- Q 4 b) Compare TTL and CMOS logic families. **06**
- Q 5 a) Enlist any four digital circuits used for industrial applications and explain working of any one digital circuit. **07**
- Q 5 b) Compare active and passive filters. **07**
- Q 5 c) Explain in detail temperature measurement using MSP 430 microcontroller. **06**
- Q 6 a) Explain with block diagram the basic functioning of MSP 430 microcontroller. **07**
- Q 6 b) Draw and describe the working principle of Servo Motor. **07**
- Q 6 c) Explain with an application the use of pumps and conveyor. **06**